



Automotive Multigigabit Ethernet (IEEE802.3ch) - Compliance Test



Darshan Mehta
Product Marketing



Partha M
System Engineer
OA PMA Subgroup Lead
ASA TCD Vice Chair
MIPI Test WG Chair



Agenda

- Automotive Ethernet overview
- Automotive Ethernet test requirement as per IEEE and Open Alliance
- New measurement requirement for Multigigabit Ethernet
- Test challenges to measure linearity, jitter measurements
- Demo of multigigabit Ethernet compliance
- System level test for automotive Ethernet
- Demo of protocol decode with non-intrusive approach of signal separation for 100BASE-T1

Automotive Trends

Safety



Sensors, Display,
Complex Architecture

Green Energy

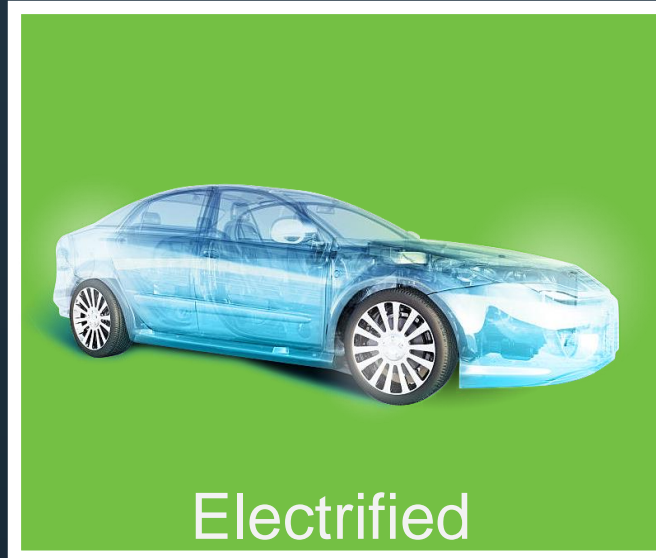

Battery, Range, Cost,
Power Electronics,

Connected



Wireless Standard,
Cloud, Connectivity

3.5 years

Service

Fewer Resource, Tighter Timeline

Motivation

Challenges

Automotive Trends

Motivation

Safety



Autonomous

Green Energy

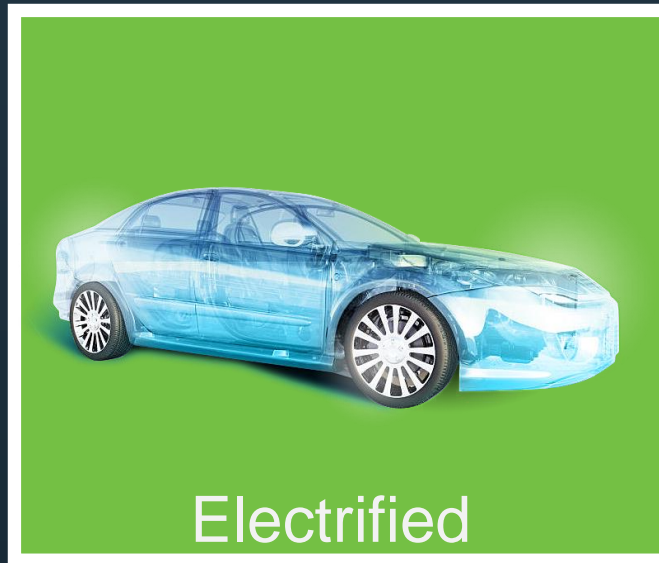

Electrified

Connected



Challenges

Sensors, Display,
Complex Architecture

Battery, Range, Cost,
Power Electronics,

Wireless Standard,
Cloud, Connectivity

3.5 years

Service

Fewer Resource, Tighter Timeline

1 Autonomous Car

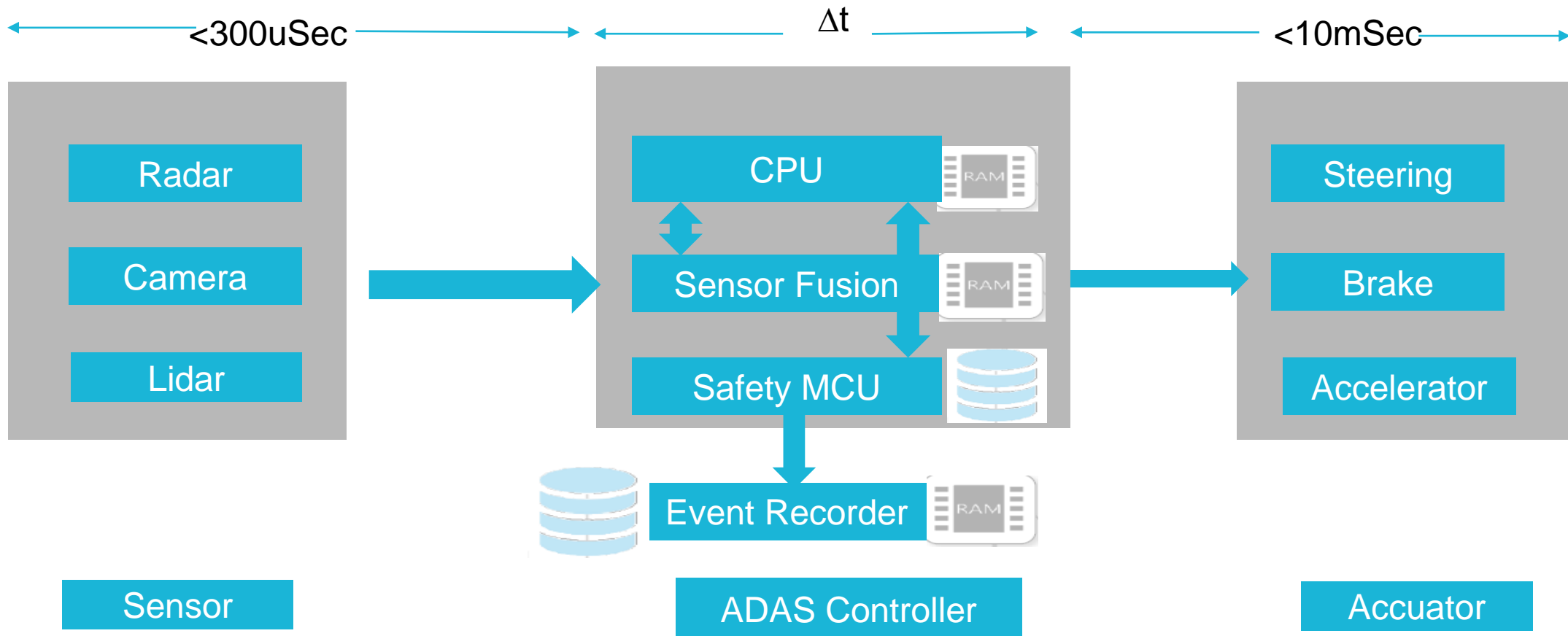

2 Architecture

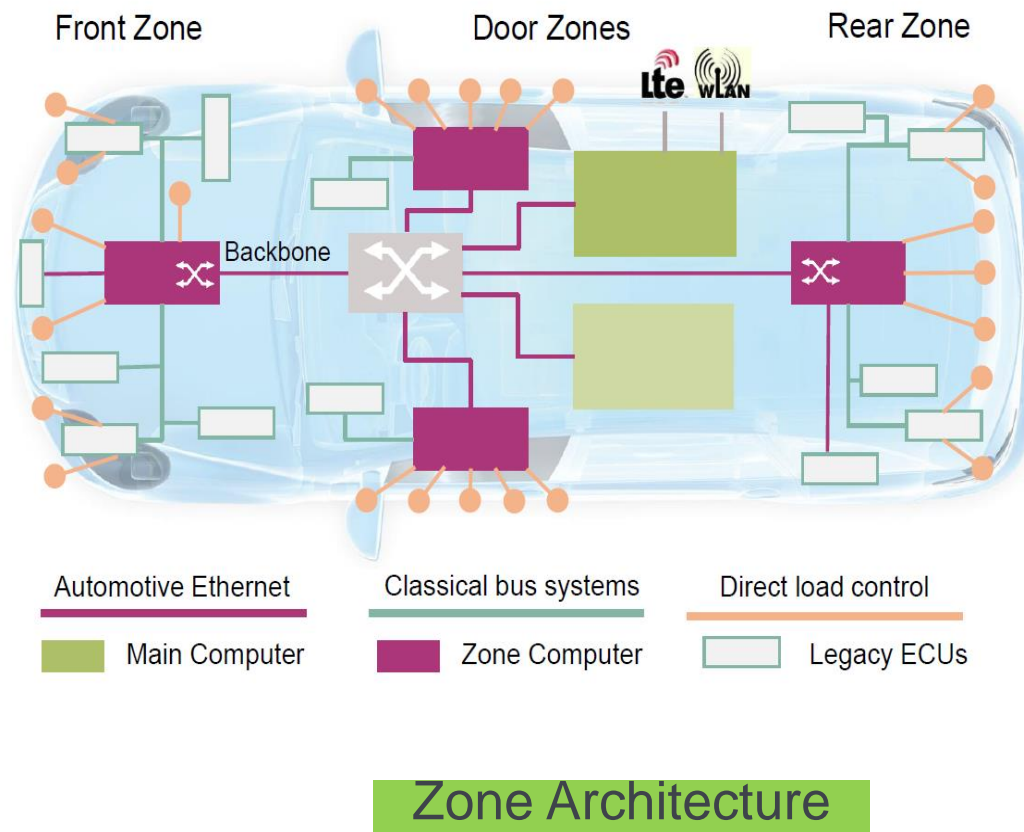
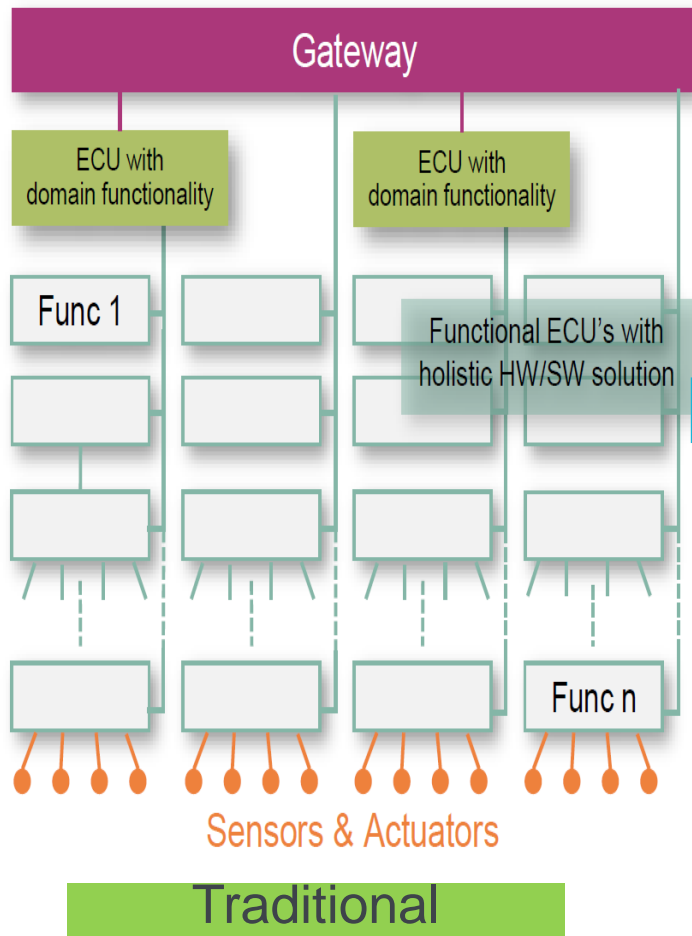

In-Vehicle Network Standards

IVN Requirement

What is IVN?

- Electronics inside the car communicate with each other over In-Vehicle-Network.
- CAN, CAN-FD, LIN, FlexRay, PSI5, CXPI etc.

IVN basic requirements:

- Reliable data transfer at Automotive harsh environment like Noise and Temperature
- EMI/EMC
- Low weight, low cost, low power

New Requirements:

- Faster In-Vehicle Network standards for newer applications
- Symmetric and Asymmetric communication

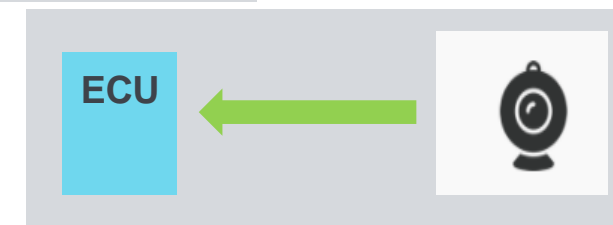
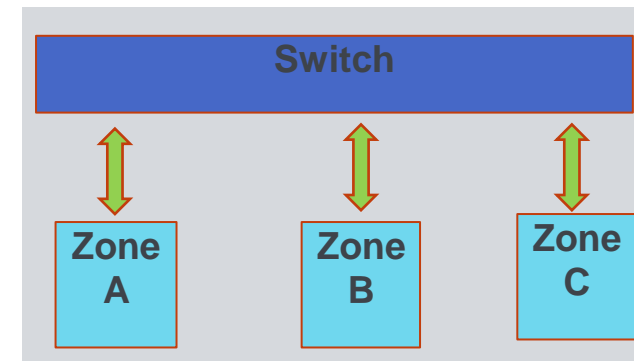
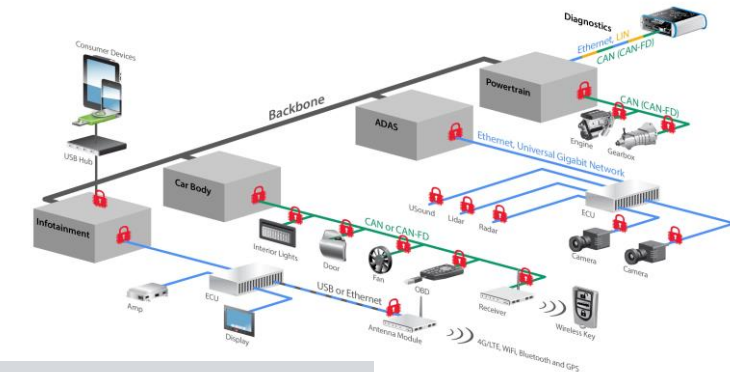
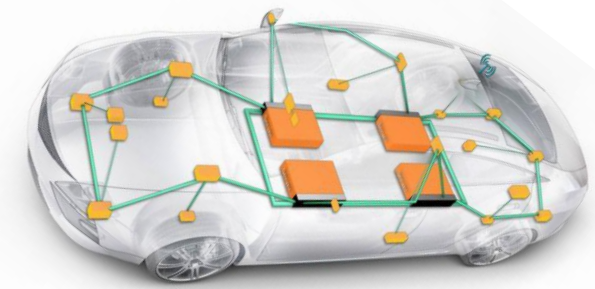

In-Vehicle Network Technologies

High Speed IVN (>10Mbps)

Symmetric IVN standards for ECU-to-ECU communication

- 100BASE-T1, 1000BASE-T1
- Multigigabit Ethernet (10G)
- 25G/50G Automotive Ethernet



Asymmetric IVN standards for Display/Camera

- Multigigabit Ethernet (Half-duplex version)
- MIPI A-PHY (upto 16G)
- ASA (upto 16G)
- HDBaseT
- FPD-Link, GMSL, GVIF, Apix



Low speed IVN (<10Mbps)

- 10BASE-T1S
- CAN-XL
- Others: CAN-FD, LIN, PSI5



Automotive Ethernet Overview

- **Standards:**

- 10BASE-T1S (802.3cg) – 10Mbps
- 100BASE-T1 (802.3bw) – 100Mbps
- 1000BASE-T1 (802.3bp) - 1000Mbps
- Multigigabit Ethernet (802.3ch) – 10Gbps
- 25G/50G Automotive Ethernet (802.3cy*)
- Multigigabit Optical Automotive Ethernet (802.3cz*)

- **Why Automotive Ethernet?**

- Derived from proven Ethernet standards
- Offers Common Architecture with multiple speed option
- Cost: Unshielded cable, Full-duplex cable reduces cost by 80% and cable weight up to 30%

- **What is the difference between Ethernet and Auto Ethernet?**

- Single pair of cable
- Full-Duplex communication
- PAM3/4 modulation

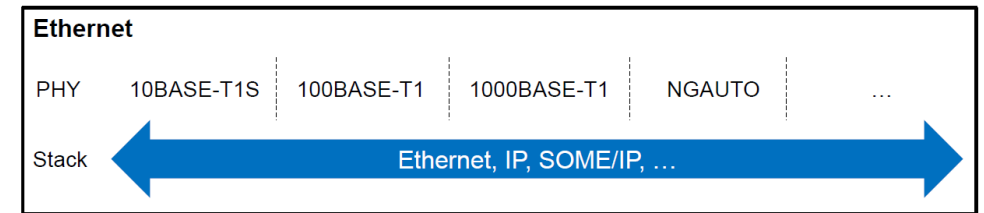
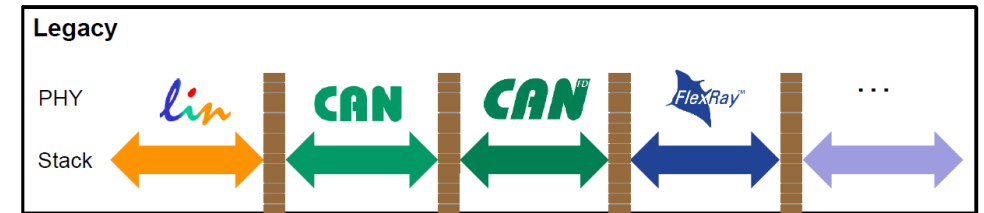

OSI	Automotive Ethernet
7 Application	Applications (HTTP, FTP, SMTP..)
6 Presentation	
5 Session	
4 Transport	TCP
3 Network	IP
2 Data Link	Network Access
1 Physical	10/100/1000/NGBASE-T1

Automotive Ethernet- 10Mbps to 10Gbps

	10BASE-T1S	100BASE-T1	1000BASE-T1	Multigigabit
Datarate	10Mbps	100Mbps	1Gbps	2.5/5/10Gbps
Symbol rate	12.5MHz	66.66MHz	750MHz	1.4/2.8/5.6 GHz
Line coding	4B/5B, DME	PAM3	PAM3	PAM4
Voltage	1Vpp	2.2Vpp	1.3Vpp	1.3Vpp
Communication	Half Duplex	Full Duplex	Full Duplex	Full Duplex
Configuration	Point to Point Multidrop	Point to Point	Point to Point	Point to Point
Cable length	15m/25m	15m	15m	15m
Cable Type	24-26 AWG 40ns	Unshielded twisted pair 15ns	Unshielded twisted pair 1.33ns	Shielded twisted pair 0.714/0.357/0.179ns

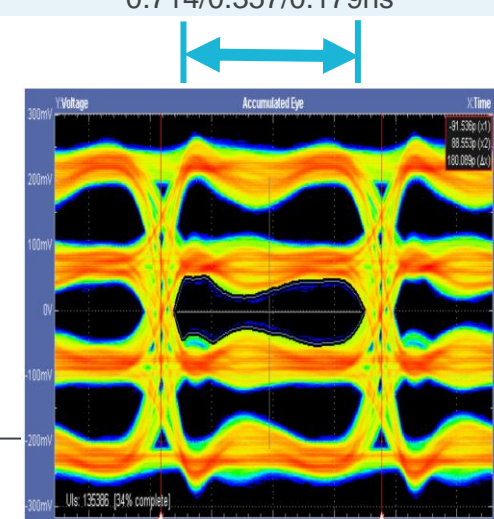
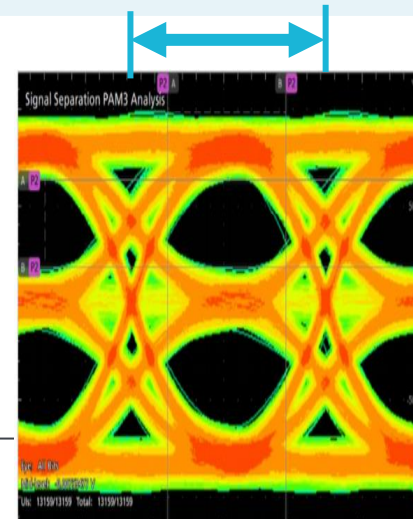
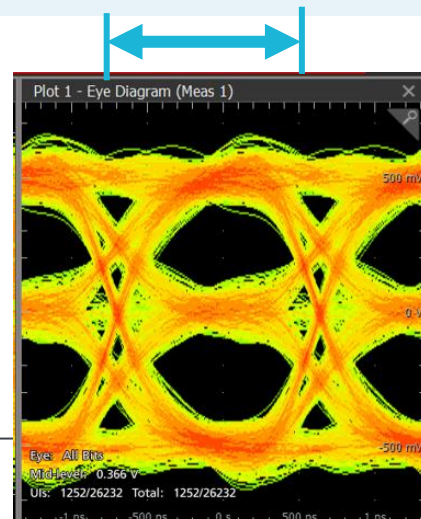

Automotive Ethernet Test Requirements



PHY layer test Requirement

- PMA Compliance Test as per IEEE/Open Alliance
- System Level Noise Test
- Protocol Timing Measurement

Automotive Ethernet Compliance



100BASE-T1

PHY and Protocol
IEEE 802.3bw

Open Alliance TC1

1000BASE-T1

PHY and Protocol
IEEE 802.3bp

Open Alliance TC12

10BASE-T1S

PHY and Protocol
IEEE 802.3cg

Open Alliance: TC14
In Progress

MultiGBASE-T1

PHY and Protocol
IEEE 802.3ch

Open Alliance: TC15
In Progress

TC8 ECU Specification

Automotive Ethernet PMA Test Specification

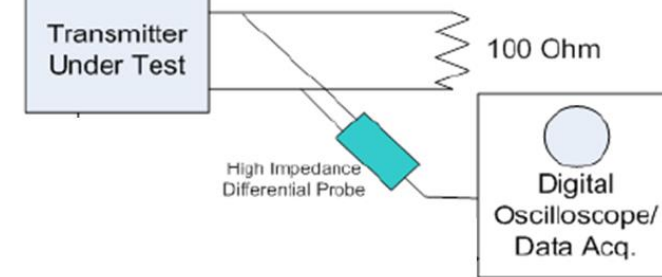

Test Name	Details/ Subtest	10BASE-T1S	100BASE-T1	1000BASE-T1	MultiGBASE-T1
Transmitter Output Droop	1) Positive Droop 2) Negative Droop	✓	✓	✓	✓
Transmitter Distortion			✓	✓	
Transmitter Linearity					✓
Transmitter Timing Jitter in Master/Slave Mode	1) RMS/p2p MASTER Tx CLK 2) RMS/p2p SLAVE Tx CLK	✓	✓	✓	✓
Transmitter MDI Jitter		✓	✓	✓	
Tx MDI Random Jitter (Master)	1) RMS/p2p MDI Jitter				✓
Tx MDI Deterministic Jitter (Master)	1) pk-pk DJ 2) pk-pk EOJ				✓
Transmitter Power Spectral Density	PSD, Power Level	✓	✓	✓	✓
Transmit Clock Frequency		✓	✓	✓	✓
Transmitter Peak differential output		✓	✓	✓	✓
MDI return Loss		✓	✓	✓	✓
MDI Mode conversion			✓	✓	
Common Mode emission			✓		

Compliance Test Workbench

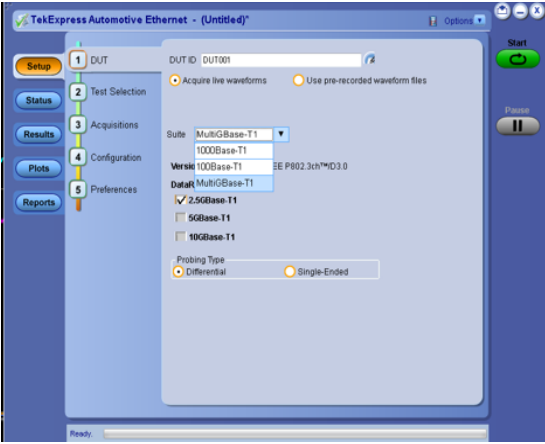

TekExpress Automated Compliance Test



DPO70K DX/SX, MSO 6B series

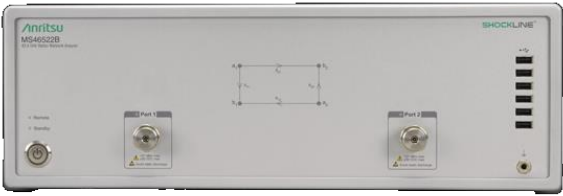
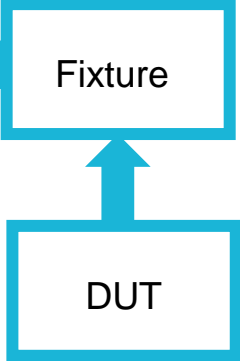

Anritsu VNA

Multigigabit Ethernet Compliance Test



MultiGBASE-T1 PMA Test Specification

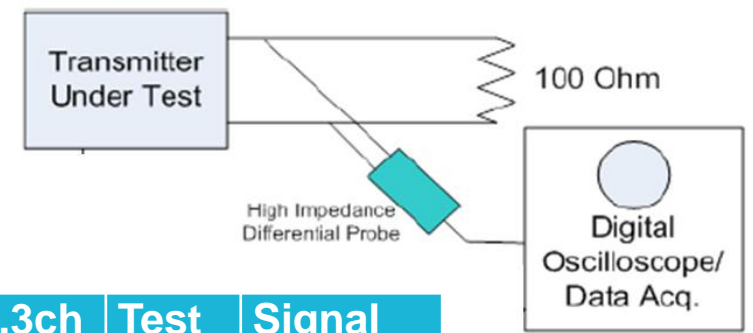

Test Name	Details/ Subtest	IEEE 802.3ch Spec ID	Test Mode	Signal Type
Transmitter output Droop	1) positive droop 2) negative droop	149.5.2.1	6	Square
Transmitter Linearity		149.5.2.2	4	PAM4
Transmitter Timing Jitter in Master/Slave Mode	1) RMS/p2p MASTER Tx CLK 2) RMS/p2p SLAVE Tx CLK	149.5.2.3	1	Clock
Tx MDI Random Jitter (Master)	1) RMS/p2p MDI Jitter	149.5.2.3.1	2	Square
Tx MDI Deterministic Jitter (Master)	1) pk-pk DJ 2)pk-pk EOJ	149.5.2.3.2	2	JP03A JP03B
Transmitter Power Spectral Density (PSD)	PSD Power Level	149.5.2.4	5	PAM4
Transmit Clock Frequency		149.5.2.6	1	Clock
Transmitter Peak differential output		149.5.2.5	5	PAM4
MDI return Loss		149.8.2.1	Slave	

Test Mode: Details

TestMode	SignalType	Signal Rate
TM6	TWO_LEVEL	43.9453125 MHz
TM4	PAM4	1.40625 GHz (2.5GBASE-T1) 2.8125 GHz(5GBASE-T1) 5.625 GHz(10GBASE-T1)
TM1	DUT TX_TCLK_175 line	175.78125 MHz
TM2- Square Wave	CLK	175.78125 MHz
TM2 - JP03A(DJ) TM2 - JP03B(EOJ)	PAM4 - 2 symbols	1.40625 GHz (2.5GBASE-T1) 2.8125 GHz(5GBASE-T1) 5.625 GHz(10GBASE-T1)
TM5	PAM4	1.40625 GHz (2.5GBASE-T1) 2.8125 GHz(5GBASE-T1) 5.625 GHz(10GBASE-T1)

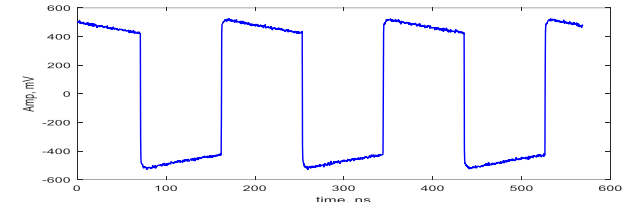

TM6

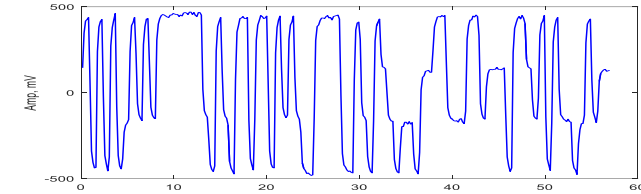

TM4

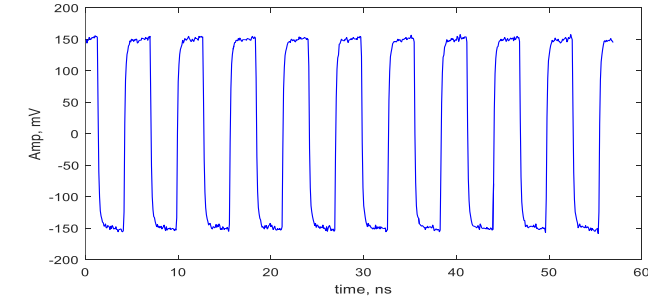

TX_TCLK_175

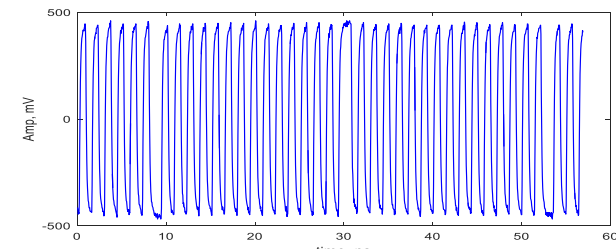

TM2 -JP03B

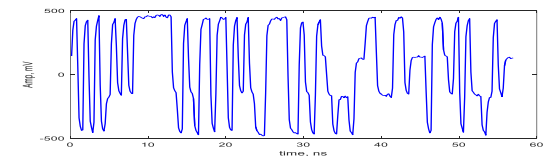

TM5

Transmitter Timing Jitter

- DUT set to Test Mode#1 and measure at DUT CLK line :TX_TCLK_175
 - 175.78125 MHz
- Spec recommends 200MHz Band Pass Filtering

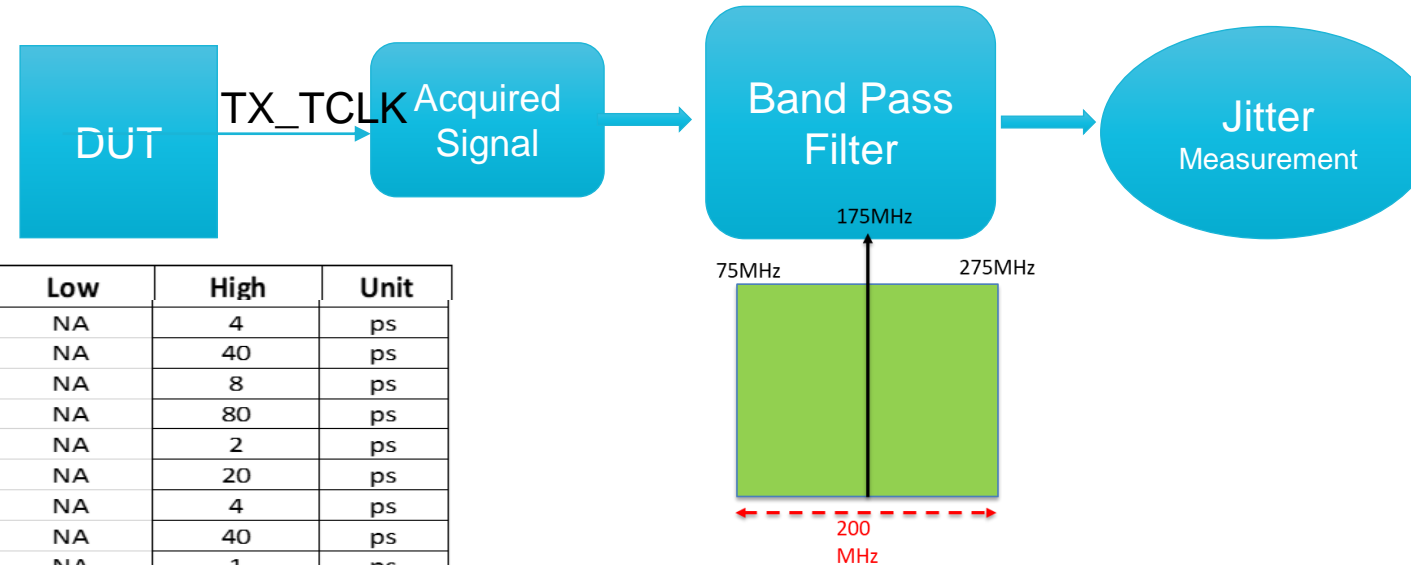
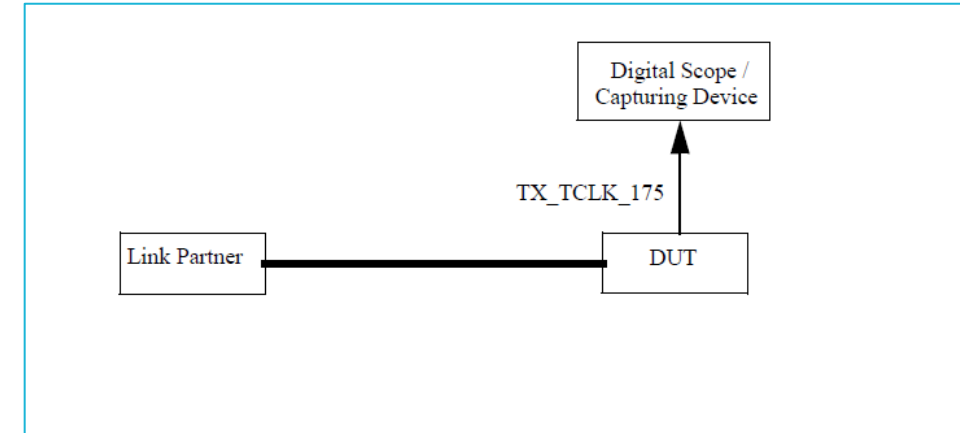

		Details/Sub tests	Low	High	Unit
Transmitter timing jitter	2.5GBASE-T1	1) RMS MASTER Tx CLK	NA	4	ps
		2) p2p MASTER Tx CLK	NA	40	ps
		3) RMS SLAVE Tx CLK	NA	8	ps
		4) p2p SLAVE Tx CLK	NA	80	ps
	5GBASE-T1	1) RMS MASTER Tx CLK	NA	2	ps
		2) p2p MASTER Tx CLK	NA	20	ps
		3) RMS SLAVE Tx CLK	NA	4	ps
		4) p2p SLAVE Tx CLK	NA	40	ps
	10GBASE-T1	1) RMS MASTER Tx CLK	NA	1	ps
		2) p2p MASTER Tx CLK	NA	10	ps
		3) RMS SLAVE Tx CLK	NA	2	ps
		4) p2p SLAVE Tx CLK	NA	20	ps

MDI Random Jitter

- DUT set to Test Mode#2 - Square Wave
- Test at MDI
- Spec recommends 200MHz Band Pass Filtering

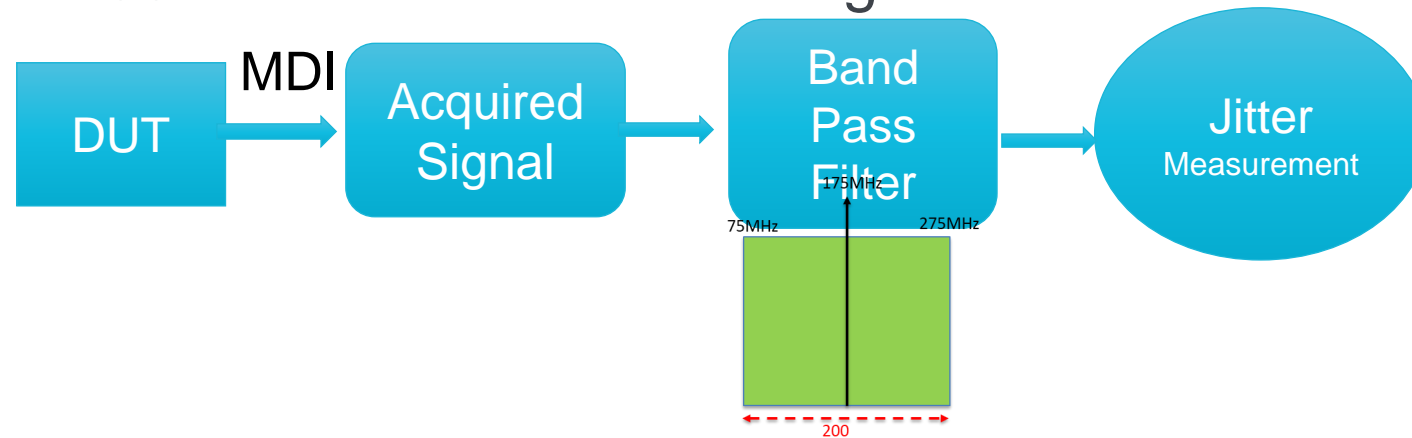

Transmit MDI random jitter in master mode	2.5GBASE-T1	1) RMS	NA	4	ps
		2) p2p	NA	40	ps
	5GBASE-T1	1) RMS	NA	2	ps
		2) p2p	NA	20	ps
	10GBASE-T1	1) RMS	NA	1	ps
		2) p2p	NA	10	ps

MDI Deterministic Jitter

- Transmitter MDI deterministic Jitter:
 - Test mode 2 with JP03A and JP03B pattern, Master mode
 - Dj: JP03A pattern: 9/S ps (pk-pk)
 - JP03B pattern: Even odd jitter: 4/S ps (pk-pk)
 - Measurement to be performed with a population of $\geq 10^7$ symbols
 - For 2.5GBASE-T1, this translates to 7.111 ms
 - Sample rate of 12.5Gsp/s, implies a waveform record of ~88 M samples

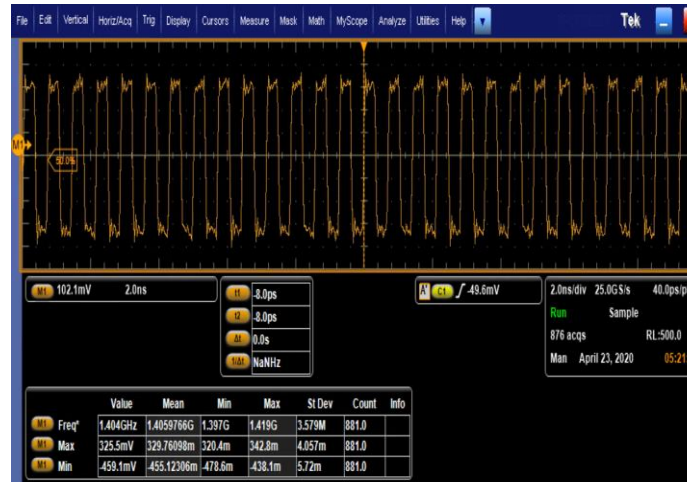

JP03A_5G

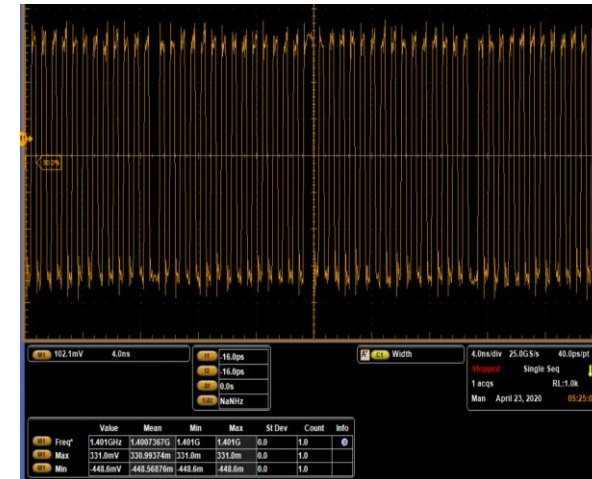

JP03B_5G

Transmit MDI deterministic jitter in master mode	2.5GBASE-T1	1) DJ pk-pk	NA	36	ps
	5GBASE-T1	2) EOJ pk-pk	NA	16	ps
		1) DJ pk-pk	NA	18	ps
	10GBASE-T1	2) EOJ pk-pk	NA	8	ps
		1) DJ pk-pk	NA	9	ps
		2) EOJ pk-pk	NA	4	ps

Transmitter Linearity

- Linear fit pulse response $p(k)$ and linear fit error $e(k)$
 - σ_e Standard deviation of $e(k)$
 - p_{max} maximum value of $p(k)$
- σ_n RMS deviation from the mean voltage

- SNDR is computed as defined below

$$SNDR = 10 \log_{10} \left(\frac{p_{max}^2}{\sigma_e^2 + \sigma_n^2} \right)$$

- Spec allows to average multiple waveform captures to remove instrument noise

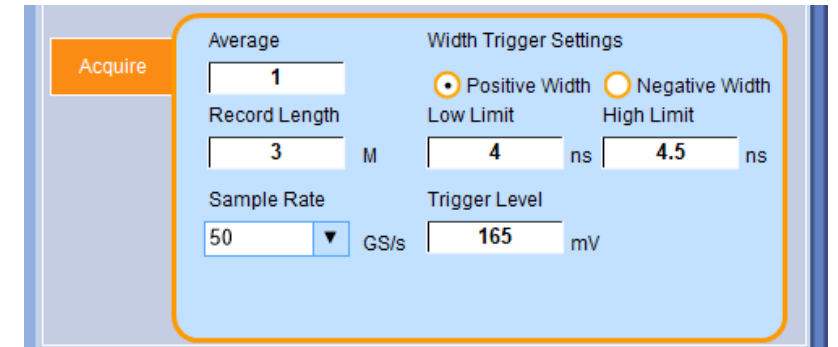
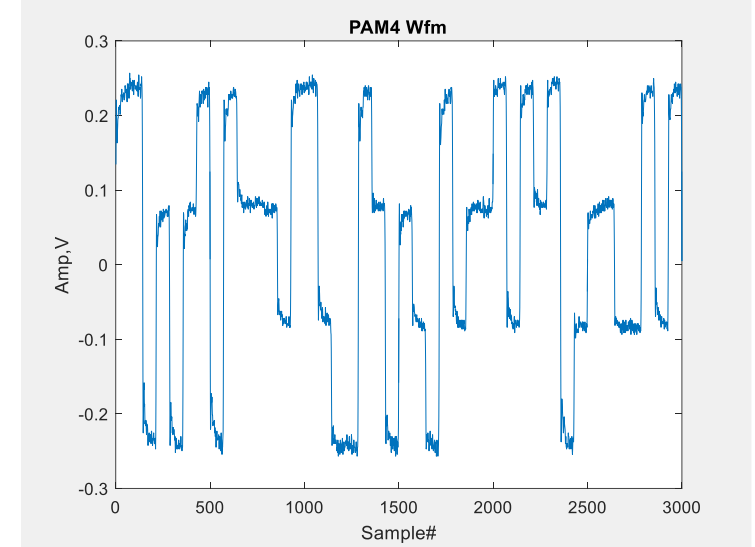

		Details/Sub tests	Low	High	Unit
Transmitter linearity	2.5GBASE-T1		38	NA	dB
	5GBASE-T1		36	NA	dB
	10GBASE-T1		35	NA	dB

Power Spectral Density

- Power Spectral Density
 - Configure Test Mode 5
 - Random sequence of PAM4 codes
 - Power level -1dBm to 2dBm

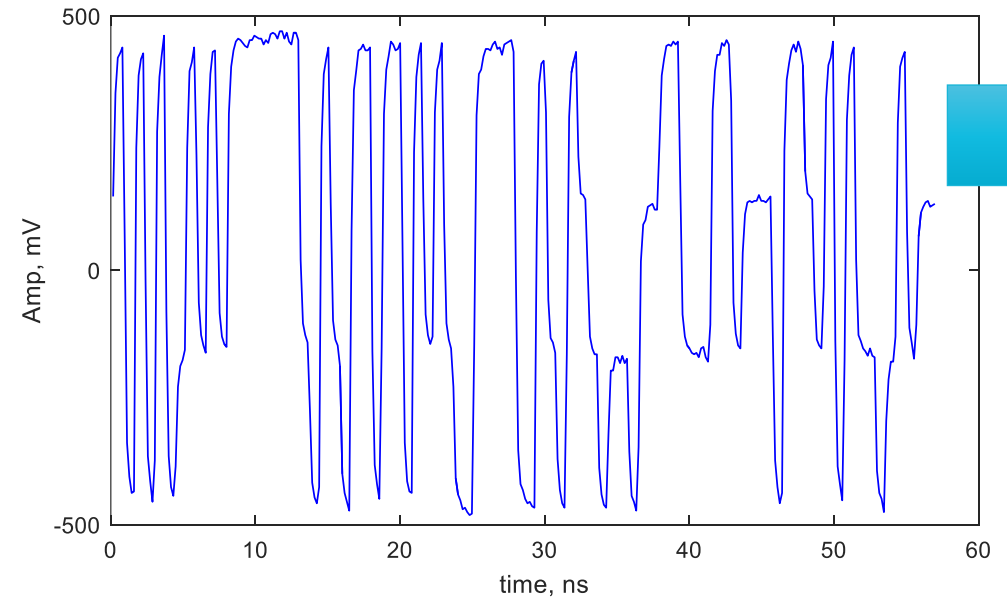
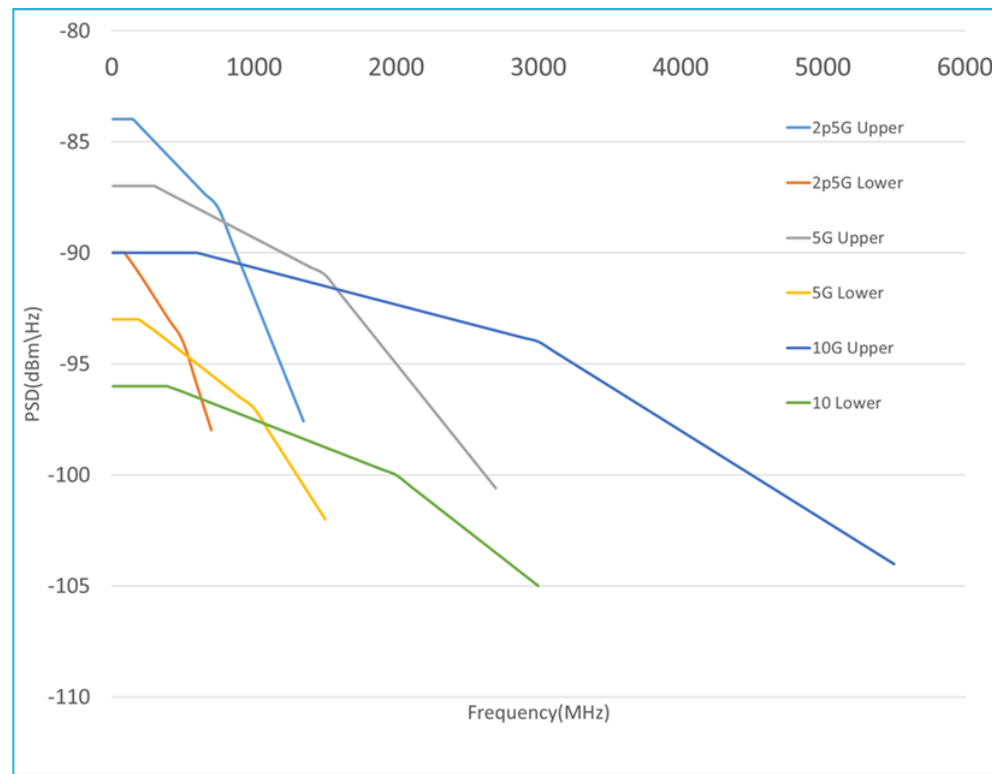

Tektronix Automotive Ethernet Solution

MultiGBASE-T1 – TekExpress Workflow

DUT Configuration



Test Selection



Measurement Configuration

The screenshot shows the 'DUT' configuration step (1) in the TekExpress Automotive Ethernet software. The 'DUT ID' is 'DUT001'. There are two radio buttons: 'Acquire live waveforms' (selected) and 'Use pre-recorded waveform files'. The 'Suite' is set to 'MultiGBase-T1'. The 'Version' is '100Base-T1 EE P802.3ch™D3.0'. The 'DataR' is 'MultiGBase-T1'. Under 'DataR', '2.5GBase-T1' is checked, while '5GBase-T1' and '10GBase-T1' are unchecked. The 'Probing Type' is set to 'Differential'.

The screenshot shows the 'Test Selection' step (2) in the TekExpress Automotive Ethernet software. The title is 'Automotive Ethernet MultiGBase-T1 Specifications'. There are 'Deselect All' and 'Select All' buttons. A list of test modes is shown with checkboxes: 'Test Mode 1 - Master' (checked), 'Transmitter Timing Jitter - Master Jitter' (checked), 'Transmitter Clock Frequency' (checked), 'Test Mode 1 - Slave' (checked), 'Transmitter Timing Jitter - Slave Jitter' (checked), 'Test Mode 2' (checked), 'Transmitter Random Jitter MDI Master Mode' (checked), 'Transmit Deterministic Jitter MDI Master Mode' (checked), 'Transmit Even-Odd Jitter MDI Master Mode' (checked), 'Test Mode 4' (checked), 'Transmitter Linearity' (checked), 'Test Mode 5' (checked), 'Transmitter Power Spectral Density and Power Level' (checked), 'Test Mode 6' (checked), and 'Maximum Output Droop' (checked). A 'Test Description' box at the bottom states: 'Transmit MDI Random jitter is measured in MASTER timing mode relative to a jittered reference, while the DUT is set to TestMode#2 with a square pattern.' There is a 'Schematic' button.

The screenshot shows the 'Measurement Configuration' step (4) in the TekExpress Automotive Ethernet software. The 'Compliance Mode' is 'User Defined Mode'. There are 'Global Settings', 'Measurements', and 'Calibration' tabs. The 'Measurements' tab is active, showing a tree view of test modes: 'Test Mode 1 - Master' (with sub-items 'Transmitter Timing Jitter - Master Jitter' and 'Transmitter Clock Frequency'), 'Test Mode 1 - Slave' (with sub-item 'Transmitter Timing Jitter - Slave Jitter'), 'Test Mode 2' (with sub-items 'Transmitter Random Jitter MDI Master Mode', 'Transmit Deterministic Jitter MDI Master Mode', and 'Transmit Even-Odd Jitter MDI Master Mode'), and 'Test Mode 4'. The 'Suite' is set to '2.5GBase-T1'. A large blue box with the text 'Either test is not selected or there are no configurations.' is displayed in the center.

Multigigabit Ethernet Compliance

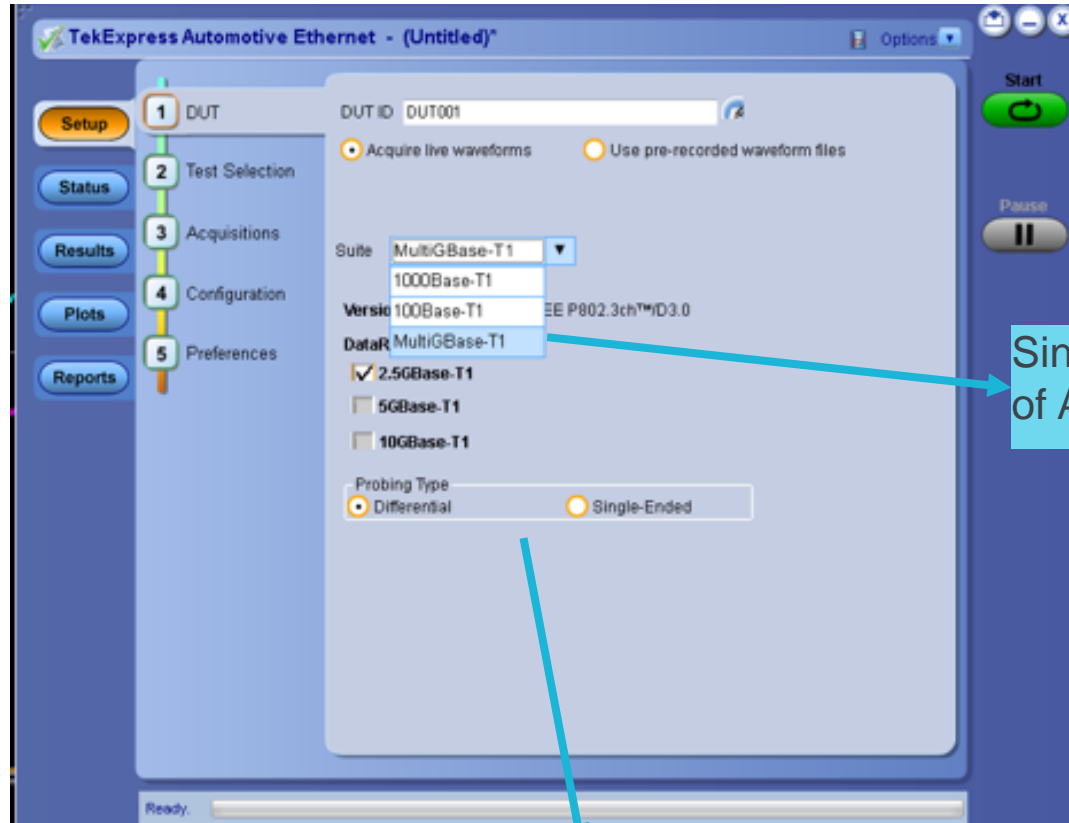

SMA Cable or Probe Support

Single UI for All Variants of Automotive Ethernet

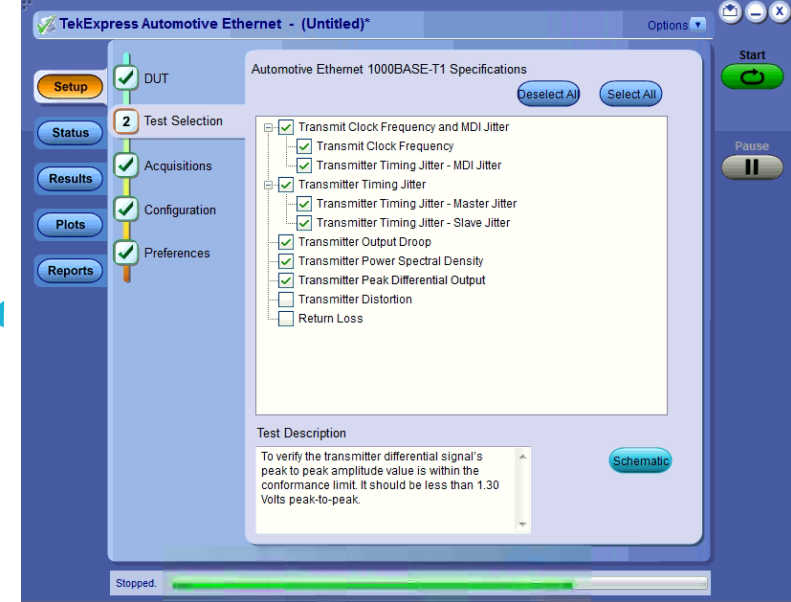

100/1000BASE-T1

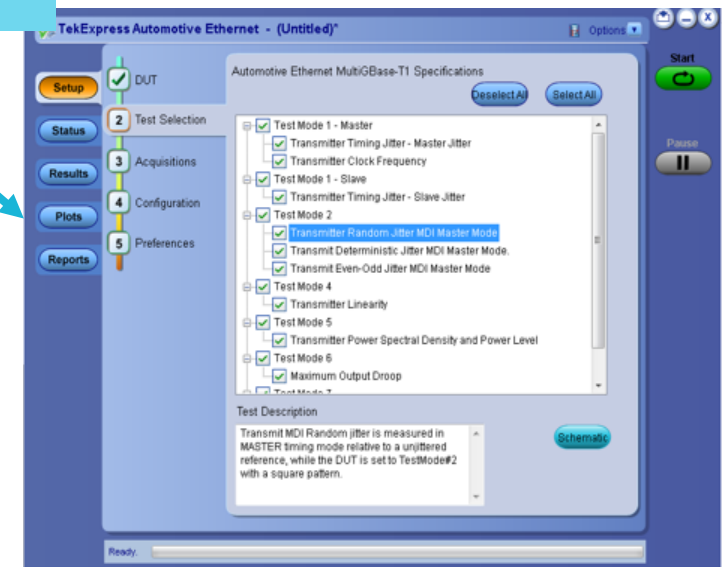

MultiGigBase-T1

Test Selection

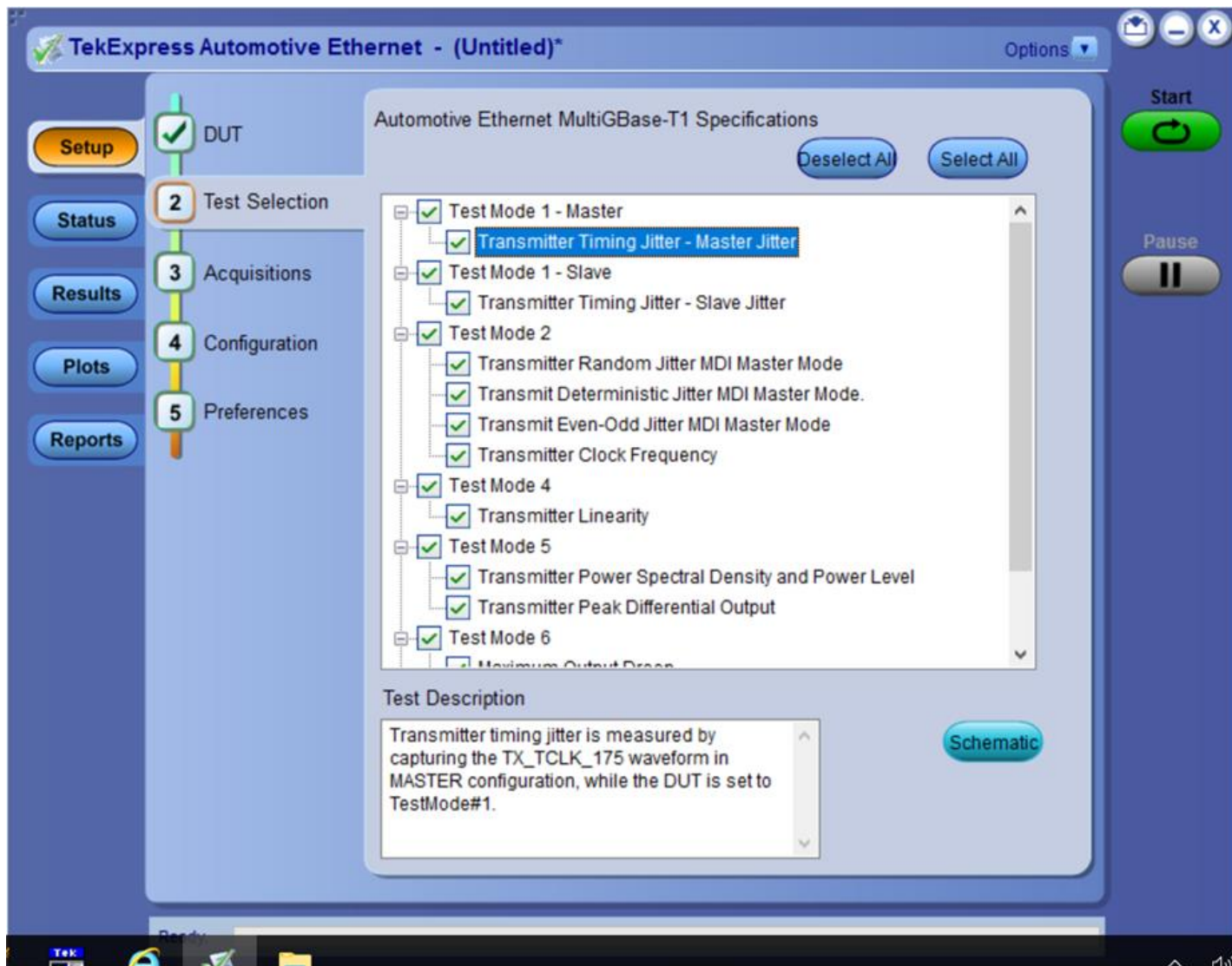

- Test tree as per Test mode
- User can run multiple test within test tree without any interruption
- Test description, schematic guides user to avoid any error

Test Configuration

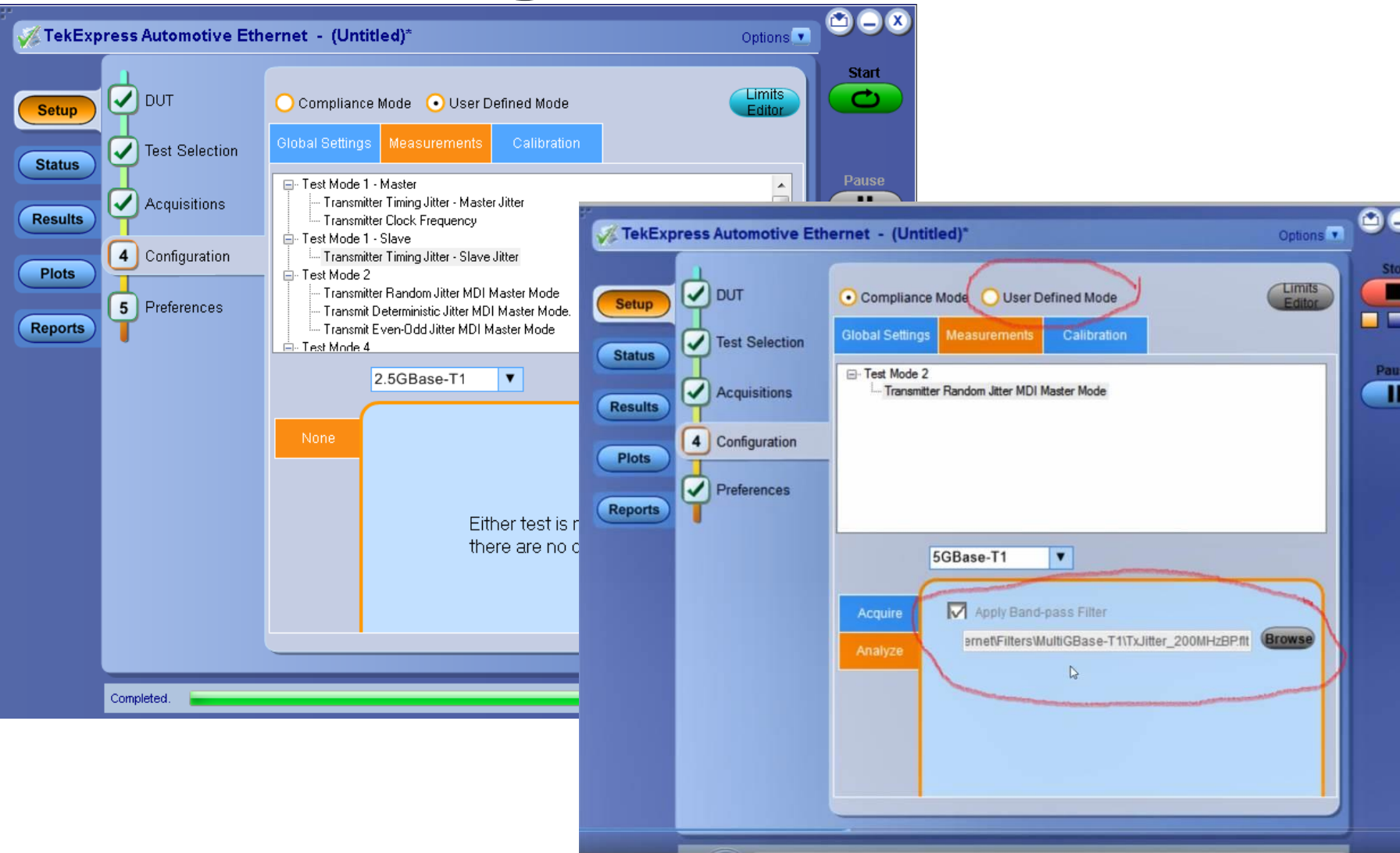

- Global Parameter
 - Sample Rate
 - Record Length
 - Number of Averages
- Power Spectral Density
 - Resolution BW
 - Start and Stop Frequency
 - Number of Spectral Averages
- Jitter Measurement
 - User defined Filter

Multirun, User Defined Acquisition Mode

- Multirun:
 - Allows for automated sequential run-throughs of selected tests
 - Test results from each iteration saved and documented in the generated report
- UDA gives full control of the oscilloscope acquisition settings to the user
 - Will skip the default setup and autoselect part of the test process
 - User can set Horizontal and Vertical scale

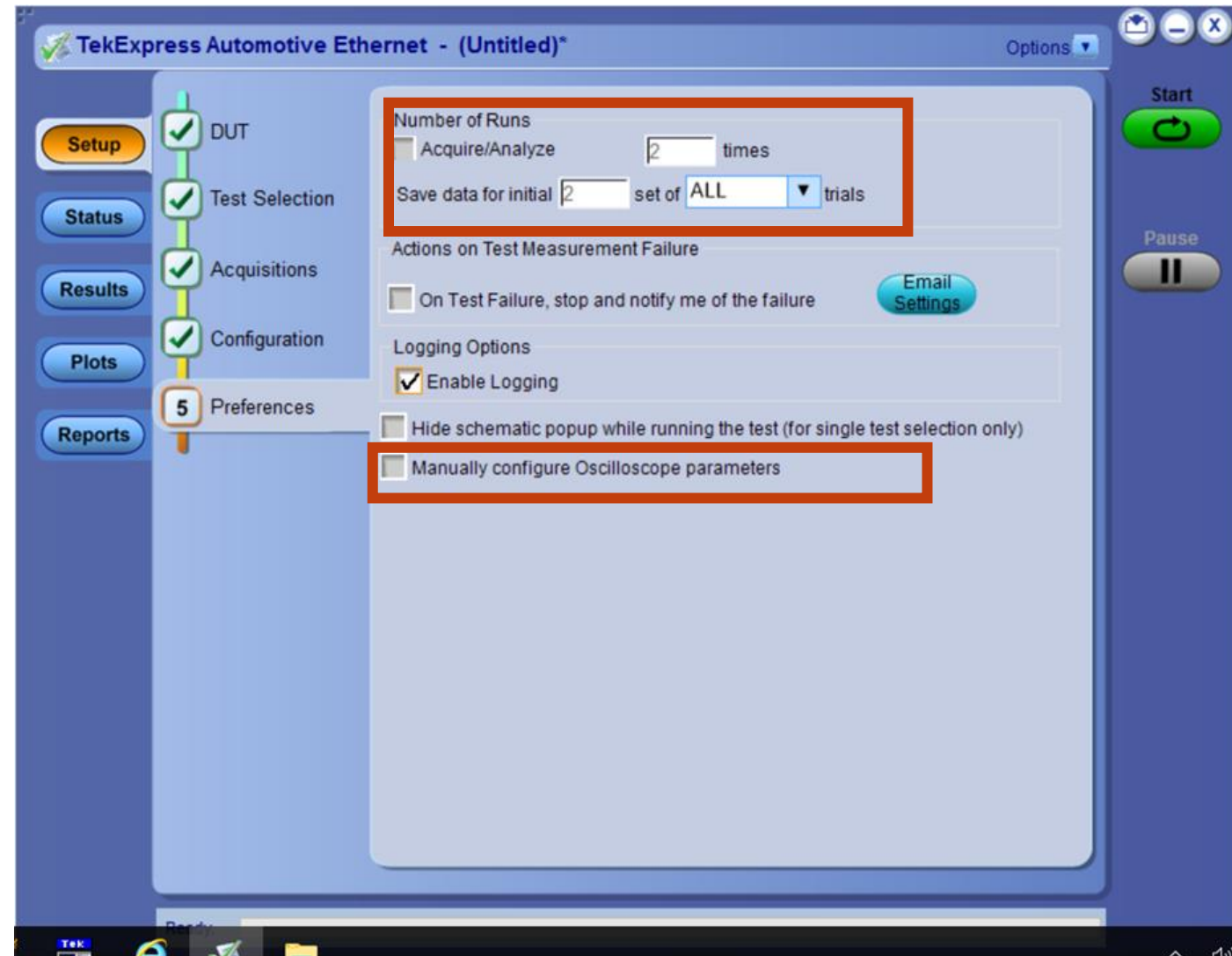

TekExpress Workflow - Results

TekExpress Automotive Ethernet - (Untitled)*

Overall Test Result: **Fail**

Test Name	Details	Pass/Fail	Value	Units	Margin
Transmitter Timing Jitter - Master Jitter	Master Jitter RMS_2.50	Fail	11.269	ps	LL: N/A, HL: -7.269
Transmitter Timing Jitter - Master Jitter	Master Jitter Pk-Pk_2.50	Fail	62.326	ps	LL: N/A, HL: -22.326
Transmitter Clock Frequency	Clock Frequency_2.50	Fail	2000.0	MHz	LL: 593.82, HL: -593.88
Transmitter Timing Jitter - Slave Jitter	Slave Jitter RMS_2.50	Fail	10.838	ps	LL: N/A, HL: -2.838
Transmitter Timing Jitter - Slave Jitter	Slave Jitter Pk-Pk_2.50	Pass	57.457	ps	LL: N/A, HL: 22.543
Transmitter Random Jitter MDI Master Mode	MDI Master Random Jitter RMS_2.50	Pass	3.112	ps	LL: N/A, HL: 0.888
Transmitter Random Jitter MDI Master Mode	MDI Master Random Jitter Pk-Pk_2.50	Pass	39.598	ps	LL: N/A, HL: 0.402
Transmitter Peak Differential Output	Peak Differential Output_2.50	Pass	0.519	V	LL: N/A, HL: 0.781

At-a-Glance Results

Tektronix TekExpress Automotive Ethernet Transmitter Test Report

Setup Information

DUT ID	DUT001	TekExpress Automotive Ethernet	10.5.0.67 (BETA)
Date/Time	2020-08-21 05:52:51	Framework Version	3.1.0.9
Pre-Recorded Mode	False	Scope Model	DPO71040HX
Compliance Mode	True	Firmware Version	18.8.1 Build 3
Suite Name	MultiClass-T1	Probe1 Model	TCA-SMA
Overall Execution Time	1:17.26	Probe1 Serial Number	N/A
Overall Test Result	Fail		

DUT COMMENT: General Comment - Automotive Ethernet DUT

Test Name Summary Table

Test Name	Pass/Fail
Transmitter Timing Jitter - Master Jitter	Fail
Transmitter Clock Frequency	Fail
Transmitter Timing Jitter - Slave Jitter	Fail
Transmitter Random Jitter MDI Master Mode	Pass
Transmitter Peak Differential Output	Pass

Transmitter Timing Jitter - Master Jitter

Measurement Details	Rate	Test Result	Low Limit	Measured Value	High Limit	Units	Margin	Run#
Master Jitter RM	2.5GBASE-T1	Fail	NA	11.269	4	ps	LL: N/A, HL: -7.269	1
Master Jitter Pk-Pk_2.5G	2.5GBASE-T1	Fail	NA	62.326	40	ps	LL: N/A, HL: -22.326	1

COMMENTS: Signal Validation is disabled. 2.5GBASE-T-1: Bandpass Filter of 200MHz bandwidth is applied. Scope Bandwidth limiting is not applicable for the selected sample rate. Edge Type: BOTH Run1: JitterMax, Min: 30.854ps, ... -82.267ps

Transmitter Clock Frequency

Measurement Details	Rate	Test Result	Low Limit	Measured Value	High Limit	Units	Margin	Run#
Clock Transmits > 2.5G	2.5GBASE-T1	Fail	1406.18	2000.0	1406.32	MHz	LL: 593.82, HL: -593.88	1

COMMENTS: Signal Validation is disabled. 2.5GBASE-T-1: Scope Bandwidth is limited to 4GHz. Run1: Minimum Frequency: 250.566MHz, Minimum Frequency: 249.683MHz

Transmitter Timing Jitter - Slave Jitter

Measurement Details	Rate	Test Result	Low Limit	Measured Value	High Limit	Units	Margin	Run#
Slave Jitter RM_2.5G	2.5GBASE-T1	Fail	NA	10.838	8	ps	LL: N/A, HL: -2.838	1
Slave Jitter Pk-Pk_2.5G	2.5GBASE-T1	Pass	NA	57.457	80	ps	LL: N/A, HL: 22.543	1

COMMENTS: Signal Validation is disabled. 2.5GBASE-T-1: Bandpass Filter of 200MHz bandwidth is applied. Scope Bandwidth limiting is not applicable for the selected sample rate. Edge Type: BOTH Run1: JitterMax, Min: 25.827ps, ... -51.827ps

Transmitter Random Jitter MDI Master Mode

Measurement Details	Rate	Test Result	Low Limit	Measured Value	High Limit	Units	Margin	Run#
MDI Master Random Jitter RM_2.5G	2.5GBASE-T1	Pass	NA	3.112	4	ps	LL: N/A, HL: 0.888	1
MDI Master Random Jitter Pk-Pk_2.5G	2.5GBASE-T1	Pass	NA	39.598	40	ps	LL: N/A, HL: 0.402	1

COMMENTS: Signal Validation is disabled. Jitter values correspond to BER of 10E-10. 2.5GBASE-T-1: Bandpass Filter of 200MHz bandwidth is applied. Scope Bandwidth limiting is not applicable for the selected sample rate. Run1: JitterMax, Min: 3.112ps, ... 3.112ps

Generated Results Report

Documents > My TekExpress > Automotive Ethernet > 1000 BaseT1 PSD > DUT001 > 20180516_05

File Name	Date modified	Type	Size
PeakDist_vs_PhaseOffset.csv	5/16/2018 5:55 PM	CSV File	1 KB
To_Rep_15mV.csv	5/16/2018 5:55 PM	CSV File	1 KB
Transmit Clock Frequency_Histogram.csv	5/16/2018 5:54 PM	CSV File	1 KB
Transmit Clock Frequency_PlotData.csv	5/16/2018 5:54 PM	CSV File	6 KB
Transmitter Output Droop_Histogram.csv	5/16/2018 5:55 PM	CSV File	18 KB
Transmitter Output Droop_PlotData.csv	5/16/2018 5:55 PM	CSV File	18 KB
Transmitter Power Spectral Density_PlotData.csv	5/16/2018 5:55 PM	CSV File	169 KB
Transmitter Timing Jitter - Master Jitter_Hist...	5/16/2018 5:54 PM	CSV File	1 KB
Transmitter Timing Jitter - Master Jitter_Plot...	5/16/2018 5:54 PM	CSV File	5,343 KB
Transmitter Timing Jitter - MDI Jitter_Hist...	5/16/2018 5:54 PM	CSV File	1 KB
Transmitter Timing Jitter - MDI Jitter_Plot...	5/16/2018 5:54 PM	CSV File	5,343 KB
Transmitter Timing Jitter - Slave Jitter_Hist...	5/16/2018 5:55 PM	CSV File	1 KB
Transmitter Timing Jitter - Slave Jitter_Plot...	5/16/2018 5:55 PM	CSV File	5,343 KB

CSV file

Details of Each Measurement

Automotive Ethernet Noise Test and Protocol Timing

Automotive Ethernet Eye Diagram

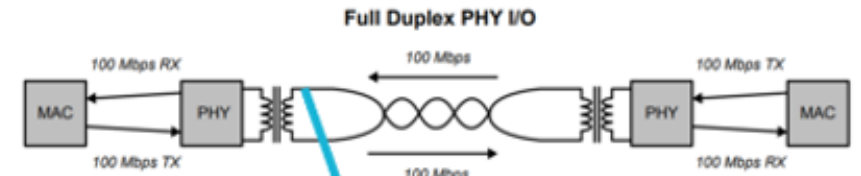

- **Why do we need eye diagram test?**

- Any High speed SERDES Signal quality is determined by Eye diagram. In case of Automotive, even for CAN-FD standards, customer perform Eye diagram to validate noise performance.
- Automotive Ethernet: customer would like to performance of link test in the presence of Noise (Signal Quality test). Eye diagram provides them insight of Link.

- **Full duplex signals:** signals overlay, meaning that connecting high impedance voltage probes yields no useful information.

- **Current available solution:**

- Cut the cable and disturb the system
- Directional coupler works on Directivity principle, would not show true Signal for Signal Integrity test
- Insertion loss, Reflection, Mode conversion loss

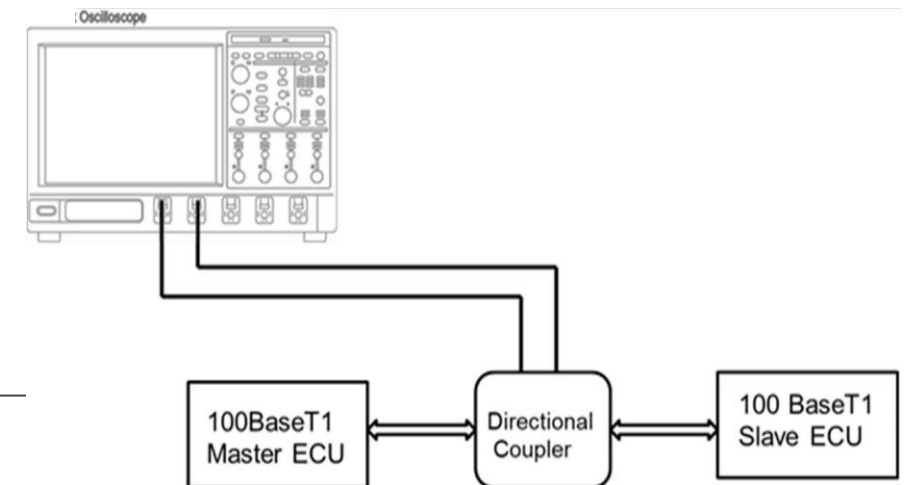
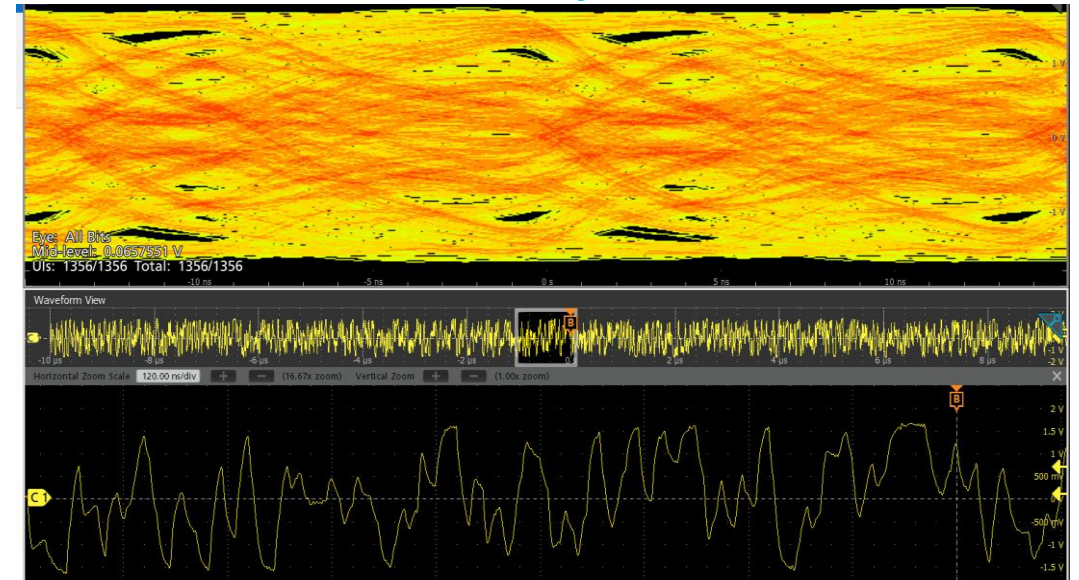

Tektronix Award Winning Signal Separation Solution

- Separates Transmitter and Receiver signals **without interfering with the circuit**
- **Non-Intrusive method** of Signal Separation: No cable cutting, no ECU loading
- Uses Voltage and Current probes
- Live Eye diagram and Protocol decode
- Added user defined Filter and Equalizer support for 100BASE-T1 and 1000BASE-T1.
- Patent pending, award winning
- Solution available for 100BASE-T1 and **1000BASE-T1**
- **Added CTLE equalizer support**

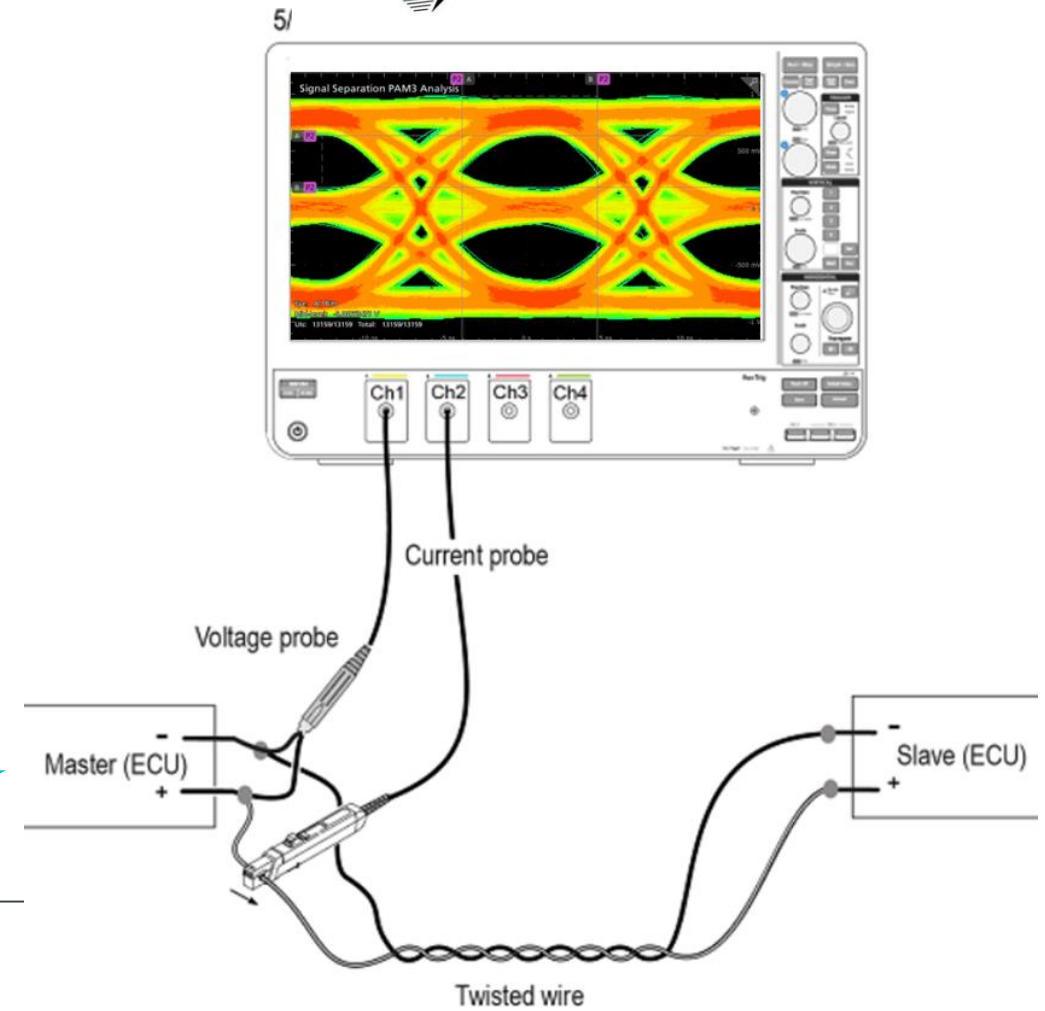

See the Real Signal with Tektronix

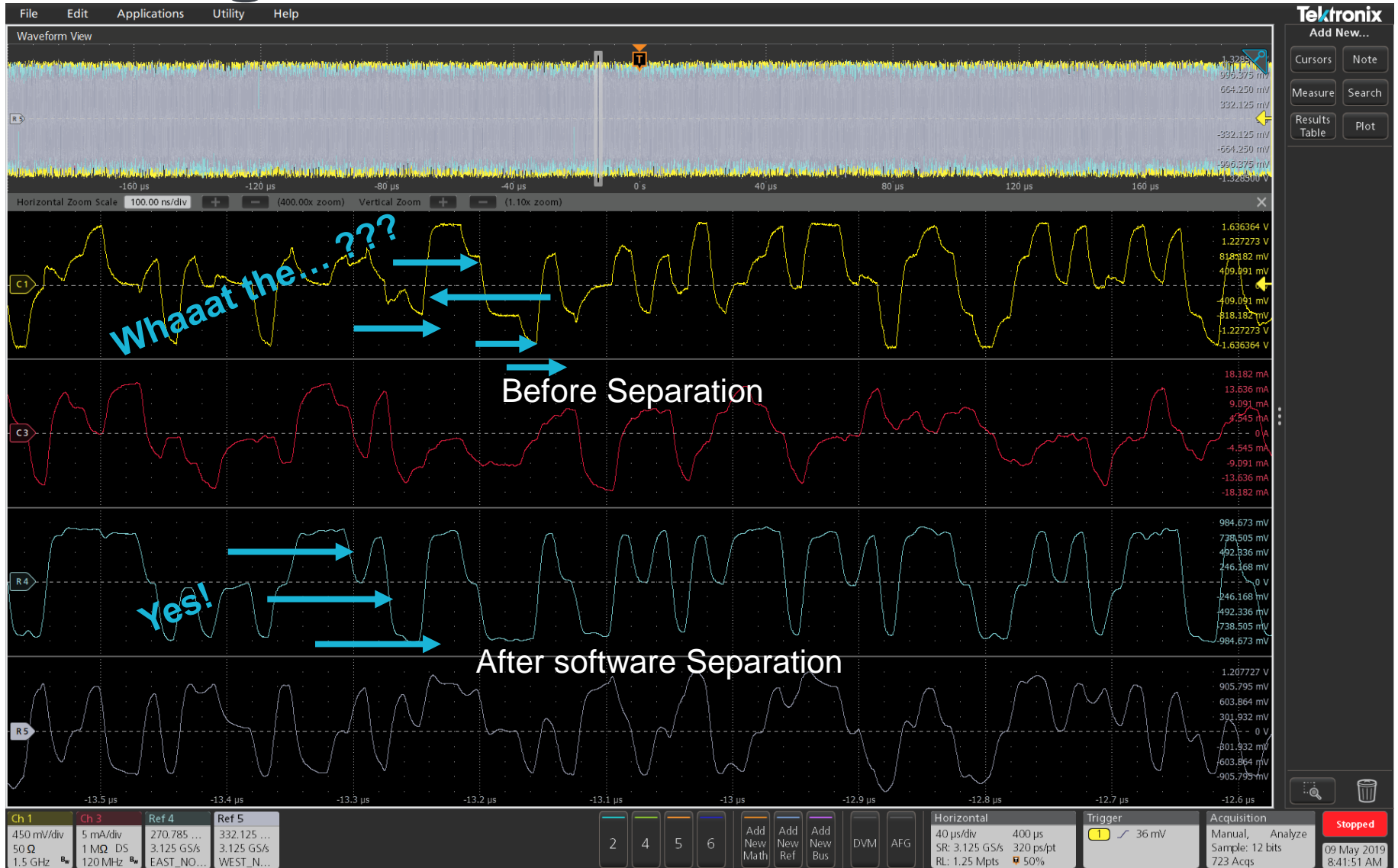

Protocol Decode

- Lets you assess protocol-level functionality (with timestamps, packet types, and logging errors)

Full-Duplex Protocol Decode



Tektronix Value proposition

- [Industry's first Compliance Application](#)
 - Cover all Automotive Ethernet variants compliance application (10BASE-T1S, 100/1000BASE-T1, MultiGBASE-T1)
- Working with major silicon companies on Multigigabit Ethernet
- Solution beyond compliance: patented [Signal separation technique](#) for System level signal integrity test, PAM4 Analysis, DPOJET
- Tektronix is leading key standard bodies like IEEE, Open Alliance, MIPI and ASA

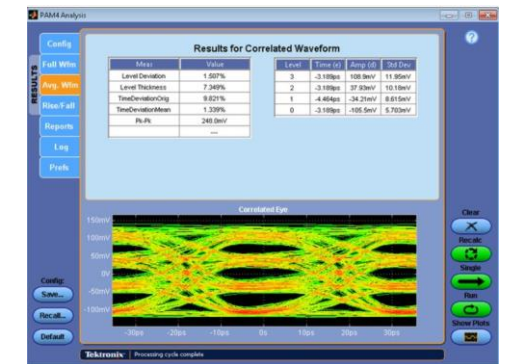
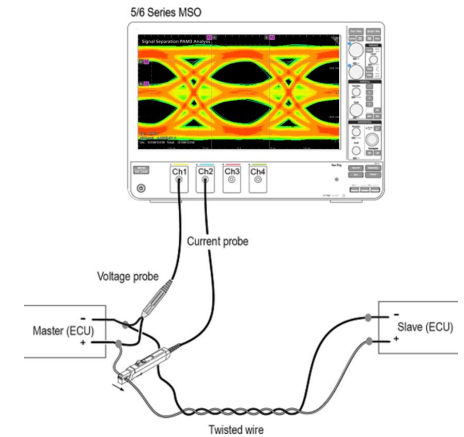

Automotive Ethernet Solution (DPO70K SX/DX)

- Oscilloscope: DPO70K SX/DX
 - 1 GHz minimum bandwidth (100BASE-T1)
 - 2 GHz Minimum bandwidth (1000BASE-T1)
 - 13 GHz Minimum bandwidth (MultiGBase-T1)
- Compliance Software:
 - BRR: 1000BASE-T1/100BASE-T1 compliance
 - AUTOEN10G: Multigigabit Ethernet compliance
- Debug: PAM4: PAM4 Signal Analysis
- Protocol Decode: SR-AUTOETH1: 100BASE-T1 Protocol decode
- Probe:
 - TDP1500- 10BASE-T1S/100BASE-T1
 - TDP3500 - 1000BASE-T1
 - P77xx- MultiGBase-T1 (Optional)
- Signal source: AFG310000 series (for 100/1000BASE-T1 Distortion test)
- Fixtures: 100/1000BASE-T1: TF-XGbT Ethernet test board, TF-BRR-CFD Clock divider
DCDP MTD 309506: Directional Coupler for Protocol decode*
MultiGBase-T1 : PCB S3401 SB 396373 Rosenberger H-MTD to SMA*

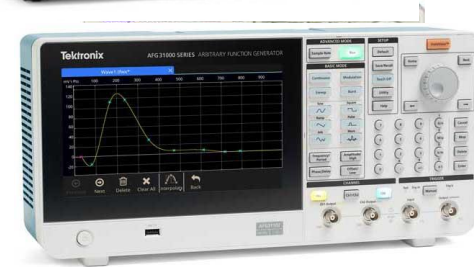

Automotive Ethernet solution (5/6B MSO series)

- Oscilloscope: 5/6B series MSO
 - 350MHz min bandwidth for 10BASE-T1S
 - 1 GHz min bandwidth for 100BASE-T1
 - 2 GHz Min bandwidth for 1000BASE-T1
 - 4GHz for 2.5GBASE-T1 and 6 GHz for 5GBASE-T1
- Compliance Software:
 - CMAUTOEN10: 10BASE-T1S Compliance
 - CMAUTOEN: 1000BASE-T1/100BASE-T1 compliance
 - CMAUTOEN10G: Multigigabit Ethernet compliance
- Debug: PAM3: PAM3 Signal Analysis with Signal Separation
- Protocol Decode: SR-AUTOEN1: 100BASE-T1 Protocol decode
- Probe:
 - TDP1500- 10BASE-T1S/100BASE-T1
 - TDP3500 - 1000BASE-T1
- Signal source: AFG310000 series (for 100/1000BASE-T1 Distortion test)
- Fixtures: 100/1000BASE-T1: TF-XGbT Ethernet test board, TF-BRR-CFD Clock divider
DCDP MTD 309506: Directional Coupler for Protocol decode*
MultiGBASE-T1 : PCB S3401 SB 396373 Rosenberger H-MTD to SMA*

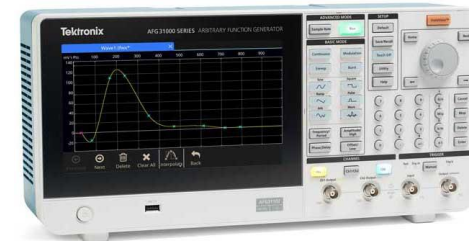

Automotive IVN References

- Automotive Ethernet: <https://www.tek.com/automotive/automotive-ethernet>
- Compliance Datasheet:
 - 10BASE-T1S: <https://www.tek.com/datasheet/10baset1s-automotive-ethernet-compliance-test-solution-option-5cmautoen10-and-6cmautoen10-datasheet>
 - 100/1000BASE-T1: <https://www.tek.com/datasheet/automotive-ethernet-test-solution>
- Videos:
 - Compliance Test: <https://www.tek.com/product-demo/demonstration-of-automated-automotive-ethernet-compliance-test-system>
 - Signal Integrity Test: <https://www.tek.com/video/automotive-ethernet-pam3-and-signal-separation-introduction>
 - CAN Bus decode: <https://www.tek.com/how-to/can-bus-decode-and-trigger-on-the-5-series-mso>
 - SENT Bus decode: <https://www.tek.com/product-demo/sent-bus-decode-and-trigger-on-5-series-mso>
- Application Note:
 - IVN standards: <https://www.tek.com/document/primer/ensuring-performance-and-conformance-vehicle-networks-new-generation-automobiles>
 - Automotive Ethernet: <https://www.tek.com/document/application-note/automotive-ethernet-see-true-signal>
 - CAN/LIN/FlexRay: <https://www.tek.com/document/application-note/debugging-can-lin-and-flexray-automotive-buses-oscilloscope>
 - SENT Bus: <https://www.tek.com/document/application-note/debugging-sent-automotive-buses-oscilloscope>

Tektronix Automotive Solution



Award winning signal separation software simplifies Automotive Ethernet testing

- IVN Solution
 - 10Mbps to 10Gbps, complete solution for Automotive Ethernet PMA Transmitter compliance.
 - Transmitter validation solution for proprietary LVDS standards like FPD-Link, GVIF etc.
 - System Level Performance Test: Noise test, Cable performance is possible only with Award winning Non-Intrusive Signal separation technique
- Automotive Radar:
 - Multichannel Analysis
 - Down-converter with in-built Local oscillator
 - Automotive Radar simulation and interference test
- Automotive Power:
 - 1 Box solution for Motor Drive Analysis
 - WBG Device test with unique IsoVue probe, AFG Double pulse generation

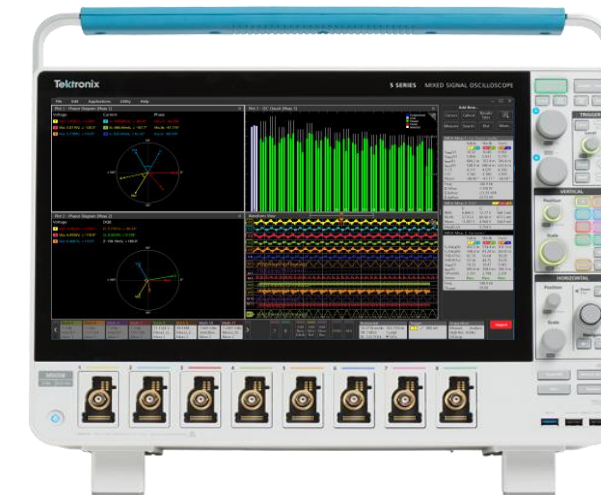

Telktronix[®]

Thank You!